

SMEC NS 2100AY-BY



Tipo: Tornio a controllo numerico

Brand: SMEC

Modello: NS 2100AY-BY

C.N.C: Fanuc 0iTF PLUS

Specifiche:

- High speed, high productivity Roller Type LM Guide Y-axis Turning Center
- High rigidity bed and Roller Type LM Guides for all feed axes
 - Super stable low-center of gravity 30° slant bed with maximized work area
 - Significantly reduced non-cutting time for high efficiency machining
 - High rigidity torque tubed and ribbed bed design to dampen vibration to allow high precision machining
 - Symmetrically designed spindle to minimize thermal growth

Informazioni tecniche

CAPACITÀ

Ø tornibile: 378 mm
Lunghezza tornibile: 520/490 mm

I° MANDRINO

Attacco mandrino: A2-6 ASA
Capacità barra: 51(A) 67 (B) mm
Velocità di rotazione: 6000 giri/min
Potenza motore: 11/18.5 Kw

II° MANDRINO

Attacco mandrino: 5 ASA
Capacità barra: 36 mm
Velocità di rotazione: 6000 giri/min
Potenza motore: 11/7.5 Kw

I° TORRETTA

Stazioni portautensili: 12
Utensili motorizzati: 20x20

II° TORRETTA

Motorizzabili: 12

PROPRIETÀ SPECIFICHE

Corsa asse X: 205 mm
Corsa asse Y: 110 mm
Corsa asse Z: 590 mm
Avanzamento rapido asse X: 30 m/min
Avanzamento rapido asse Y: 10 m/min
Avanzamento rapido asse Z: 36 m/min



Machine Design

Roller type LM Guides used for all feed axes supports heavy duty cutting and the excellent rigidity provides superior productivity

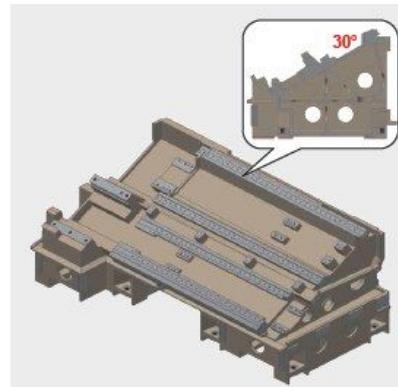
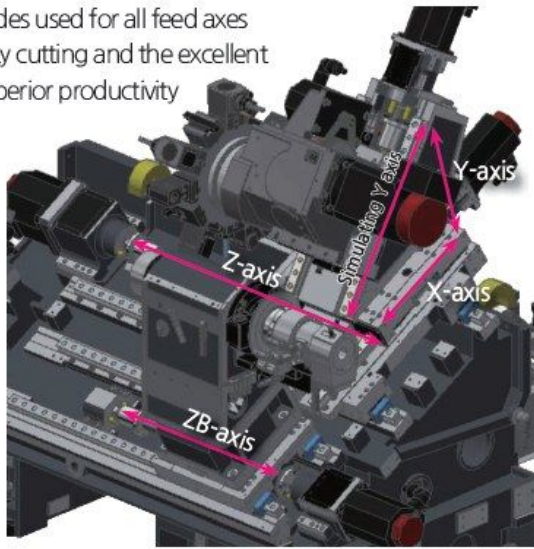

30° slant bed provides excellent stability during heavy duty cutting

The 30° slant bed with high-torque tubing and ribbed structure provide superb rigidity against twisting and bending, dampening vibration during heavy duty cutting for high precision machining

The use of a slant bed allows for easier access to the workpiece and excellent chip discharge

Model	Main chuck size	Travel (mm)				Rapid traverse (m/min)			
		X-axis	Y-axis	Z-axis	ZB-axis	X-axis	Y-axis	Z-axis	ZB-axis
NS 2100AY/ASY	6"	205	110(±55)	590	590	30	10	36	36
NS 2100BY/BSY	8"	205	110(±55)	590	590	30	10	36	36

Wedge type Y-axis with superb cutting performance

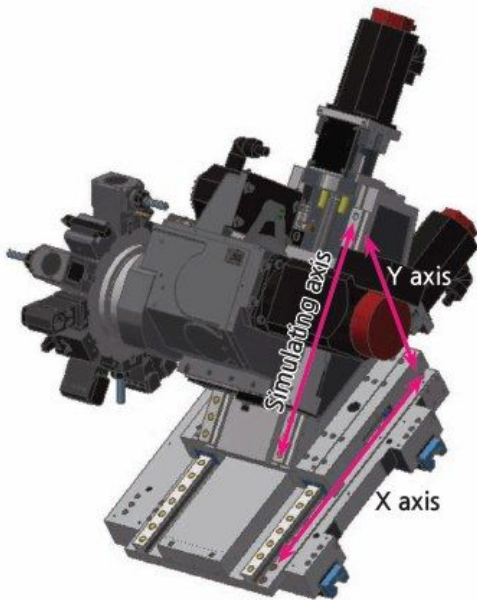

- Side milling, off-center drilling
- Wider off-center work range
- Complex shape machining with a single setup

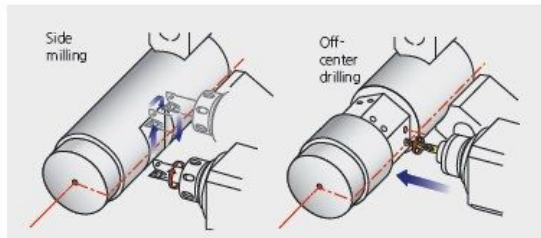

Category	Unit	NS 2100SY
No. of tool positions	ea	12(24)
Turret type		BMT45
SHANK & BORING BAR SIZE	mm	□20×20, Ø32
Turret indexing time (1station/full turn)	sec	0.15/1
Rotary tool speed	rpm	~6,000
Rotary tool motor power (max/cont)	kW	5.5/3.7
Rotary tool torque (max/cont)	N.m	35/17.7

Spindle

